

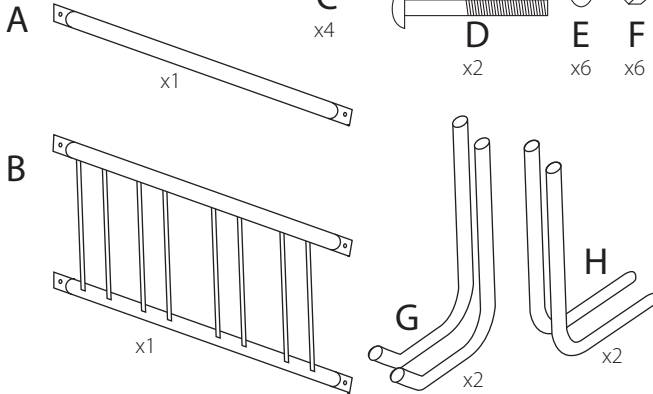

Single Sided Bike Rack Assembly Instructions

Parts



To assemble

1. Start by placing one J-frame(G) and one support frame(H) onto the bike brace(B) front and back on one side. Line up holes and secure with bolts and washers.
2. Then repeat the same process on the other end of the bike rack.
3. Now place the outside bike brace(A) onto the J-frame and secure with bolts.
4. Attach anchors (see anchor installation instructions).

IMPORTANT NOTE: Work one side at a time and do not tightly secure bolts until bike rack is fully assembled.

1

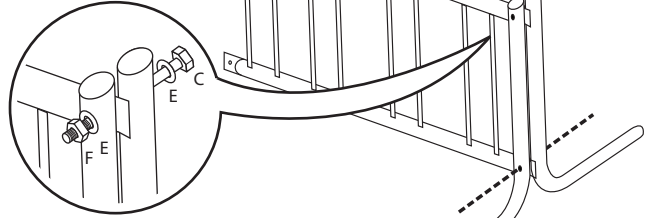

2

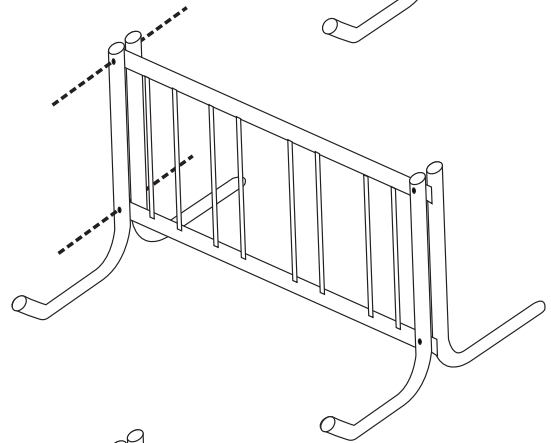

3

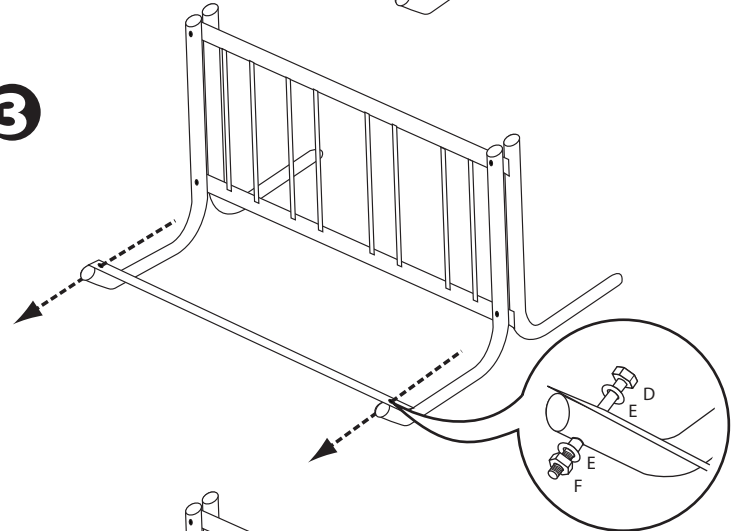

4

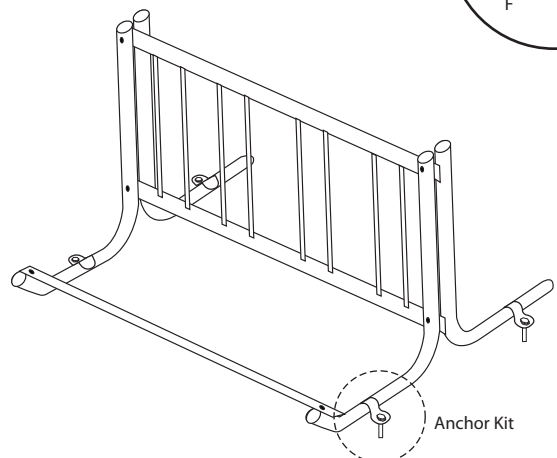

If you need any additional help with this product please call us at
1-800-231-0329.



Bike Rack Anchors Installation Instructions

Parts

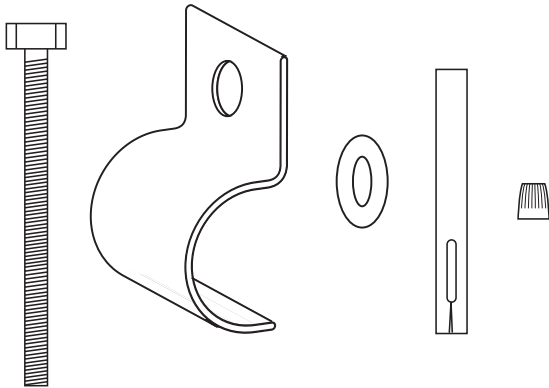

Assembled

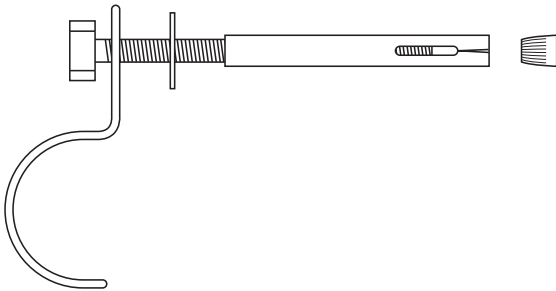

IMPORTANT NOTE:

You need to use anchor bolts when you are securing items to concrete or cement blocks. There is a wide variety of anchor bolts and each has a distinct function. The same requirements for drilling the hole and hole preparation span the entire spectrum of anchor bolts--they all rely on friction between the metal anchor and the concrete to hold them in place. Therefore, you cannot allow concrete dust to remain in the hole and reduce the friction bond needed to hold the anchor bolt in place.

Depth $3\frac{1}{4}$ "
Masonry bit $\frac{1}{2}$ "

Instructions Things You'll Need:

Safety glasses	Anchor bolt
Hammer drill	Anchor bolt hardware
Masonry drill bit	Hammer
Round wire brush	Socket wrench
Hand-operated air bulb	Socket set

 Always wear safety glasses when using a drill.

1. Once the Bike Rack is in place and you have used the clamps to mark your desired holes, look at your anchor bolts to determine the correct-size masonry drill bit needed and the depth you need to drill the hole. Insert the $\frac{1}{2}$ " masonry drill bit into the hammer drill, set the depth gauge to $\frac{3}{4}$ " and put on your safety glasses.
2. Drill the hole into the concrete. Stop drilling when the depth gauge contacts the concrete's surface.
3. Remove debris from the hole by inserting a round wire brush into the hole, rotating the brush handle and pulling the wire brush out of the concrete.
4. Insert the nozzle of the air bulb into the hole in the concrete and push the nozzle to the bottom of the hole.
5. Squeeze the air bulb to clear the hole of concrete dust. Stop forcing air into the hole when there is no more dust emitting from the hole. This may also be done with a shop vac.
6. Place bolt through the clamp. Place the washer over the threaded end of the anchor bolt and then thread the anchor bolt sleeve until the top of the hex nut rests flush with the top of the anchor sleeve. Screw the anchor nut last with the tapered end facing into the sleeve.
7. Push the anchor bolt into the hole you drilled in the concrete, with the clamp securing the bike rack.
8. Hit the nut with a hammer to force the anchor bolt to the bottom of the hole.
9. Place the $\frac{5}{8}$ " socket onto the socket wrench and tighten the bolt with the wrench until secure.

If you need any additional help with this product please call us at
1-800-231-0329.