

# Designer Metal Bench

## Parts Include:

- A. 2 Leg Frames
- B. 1 Back Panel
- C. 1 Seat Panel
- D. 4 Seat Screws
- E. 4 Back Screws
- F. 4 Concrete Anchors
- G. 8 Metal Washers
- H. 8 Plastic Washers
- I. 8 Lock Washers
- J. 4 Leg Clips
- H. Hexagonal wrench

**Additional tools needed:**  
Drill and concrete drill bit

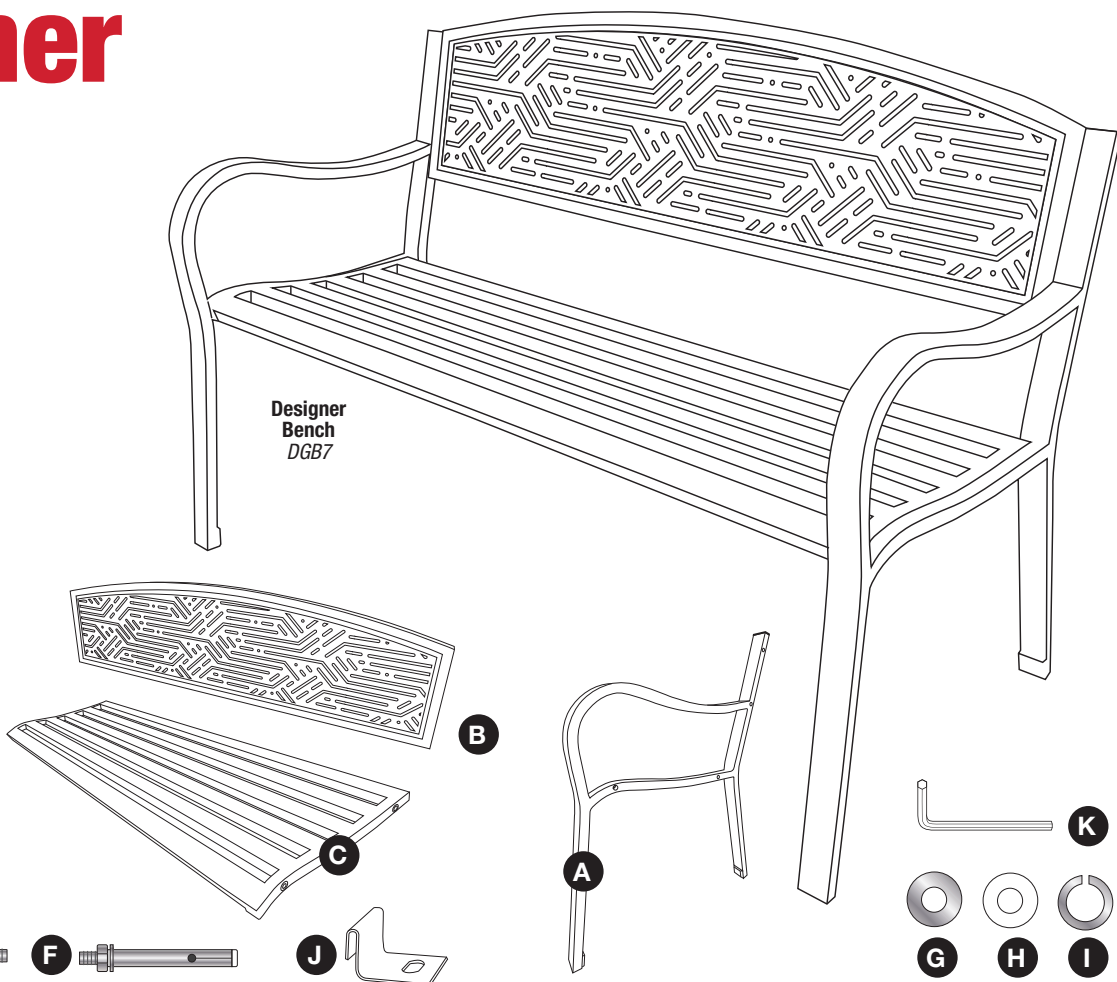

## GREAT AMERICAN'S DESIGNER BENCH:

- ★ Assembles in minutes!
- ★ Powder Coated Finish over Rust-resistant Steel
- ★ Unique "Branches" Design adds instant outdoor appeal

## Bench Assembly:

Examine all packing material before discarding, or you may lose important components.

1. Assemble bench on a soft, level surface to avoid scratching parts.

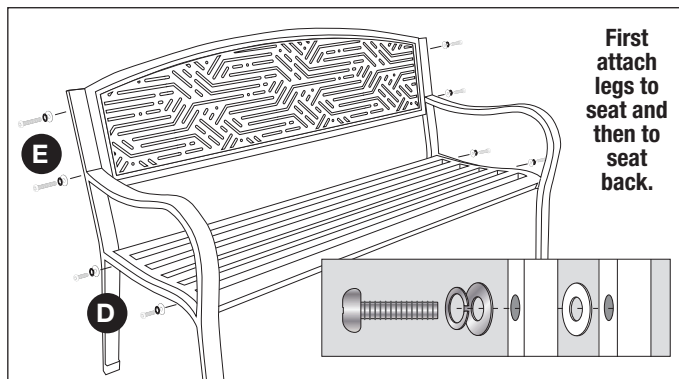

2. Use the provided wrench (K) to attach one leg frame (A) to one end of the seat panel (C). Slide a screw (E) through a lock washer (I), then a metal washer (G) and through the hole in the leg. Slide the plastic washer (H) between the leg and the seat panel before finally tightening the screw into the seat. Repeat with the other leg. Do not tighten completely until the entire bench is assembled and sitting square on the floor.

3. Attach the leg to the seat back (B) in the same manner as the seat using the longer screws (D). Set the bench on the floor, and adjust the legs until they all sit flush and square. Finally tighten all screws.

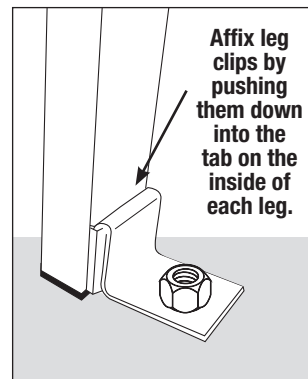

4. Optional: To Surface Mount, attach bench to concrete surface by clipping a leg clip (J) to the tabs on the inside of each leg. Determine your bench location and drill 4 holes into the concrete. Unscrew bolts from concrete anchors (F) and insert anchors into the holes. Position leg clips over each hole and insert bolts through the clips and into the anchors in the concrete. Tighten bolts to fully secure.

